



Issue 1

March 2004

## **MOVING SASH INTERFERENCE DETECTION** *– AN ASSET OR LIABILITY?*

Un-published

*At this time*

Date of Publication

***Publication Title***

Volume #, Number#5

**This document is intended to be included in a manual currently being prepared for laboratory and fume hood designers, owners and specifying engineers. The intent of the document is to present fume hood and design concerns, that if properly addressed before procurement, will result in a reduction of risk to the laboratory user, hardware designer, and especially the laboratory design professional.**

*This document is transmitted to you in an electronic format so you can click on and view the web page html references that are imbedded and included in the body and footnotes of the publication. These are links to the various manufacturers or representatives web publications, representing information extracted from the manufacturer's source information.*

This paper deals with fume hood lower air foil design, safety ledge design and design intent, and moving sash interference detectors that are installed on the bottom of fume hood sashes and are intended to stop the closing motion of the sash when the detector system senses some obstruction as it closes.

## HISTORICAL CONCERNS AND SIGNIFICANT FINDINGS

In 1950, W. G. Stockdale<sup>1</sup>, Oak Ridge National Laboratory, presented in the 2.1 panel discussion following Carlton P. Roberts<sup>2</sup> excellent Session 2 presentation, ONRL's<sup>3</sup> findings associated with the operation of fume hoods with a face velocity of 50 lfpm. He stated, "**We do not recommend a hood with a face velocity of 50 fpm for all purposes**" going on to say "**such a hood does have a place in the chemistry laboratory.**" Stockdale continued in this presentation and shared significant ONRL findings that, when incorporated into a fume hood, yielded much improved capture containment performance, with results and findings based on metered air flow rates, titanium tetrachloride smoke studies, and motion pictures made of the smoke movement, enabling study of the result for a permanent record. The several improvements that were discussed all impacted the aerodynamic aspect of air flowing into the hood as it had to do with entrance features. The features included sidewall posts and a front edge, geometry of such posts and edge sections, hood work surface, safety shelf and the lower hood entrance foil, and all of these aided in elimination of fugitive emissions from the hood, which were in many cases radioactive, lacking odor, color, or other distinguishing features that could be used to warn a user, and often posing a silent but acute hazard to one's health. The stated goal was, "**These air foils, first located along the sides and later along the front edge, reduced turbulence and give a more parallel [uniform laminar like] air flow into the hood.**"

The first successful fume hood design were of the vertical rising sash type and rested on a granite flat work surface. Figure 1 indicates such a slab base that was made from epoxy in the 1960s, and had a hood installed. As one would imagine, when spills occurred within the hood with a flat work surface, the spilled liquid always flowed out of the hood in to the room, a situation that allowed contamination of an entire lab where radioactive materials were in use.



**Figure 1- Work Surface Without Safety Ledge or Perimeter Strip.**

<sup>1</sup> *Proceedings, Laboratory Design for Handling Radioactive Material*, National Research Council, Building Research Advisory Board, Research Conference Report No. 3, November 27, 1951; page 46 – 48, 23 through and the discussion of the safety shelf feature on pages 47 and 48. The entire conference report, available in a PDF file, can be downloaded at [www.nrc.gov](http://www.nrc.gov) or transmitted to recipient upon request to [swiki@accuair.com](mailto:swiki@accuair.com).

<sup>2</sup> Roberts, with the firm of Voorhees, Walker, Foley and Smith located in New York City, published in *Proceedings, Laboratory Design for Handling Radioactive Material*, National Research Council, Building Research Advisory Board, Research Conference Report No. 3, November 27, 1951; page 23 through 39.

<sup>3</sup> Oak Ridge National Laboratory, Oak Ridge, TN



Figure 2 - Work Surface With Perimeter Strip Attached.

To overcome this problem, scientist took to installing a bounding perimeter strip of material on the slab top before setting the hood on the slab. Figure 2 illustrates a basic flat epoxy fume hood modified to produce a spill retainer feature. This was from a 1960's fume hood. The incorporation of a spill retainer in the pan of the hood however gave rise to troubles caused by flow induced rolling eddy currents, that drew vapor from the base of the hood forward to the inside edge of the forward retainer lip. This aggravated and promoted fugitive emission leakage from the hood at the base, even with fume hoods that attempted to operate with uniform constant velocity air flow parallel into the hood, one of the conditions necessary for maximum capture containment in the hood. This problem as well as its solution was recognized with Stockdale stating "The incorporation of a spill retainer in the pan of a hood continued to give trouble with eddy currents even with the bottom airfoil. To overcome this, the safety shelf idea was incorporated. This is shown in the cross sectional view of the hood in Fig. 2.1.8 [Figure 3 below]. This safety shelf is 6 in. wide and, in conjunction with the bottom airfoil, completely eliminates turbulence in the front and bottom of the hood. An enlarged section of the safety shelf and bottom airfoil is shown in Fig. 2.1.9 [Figure 4 below].

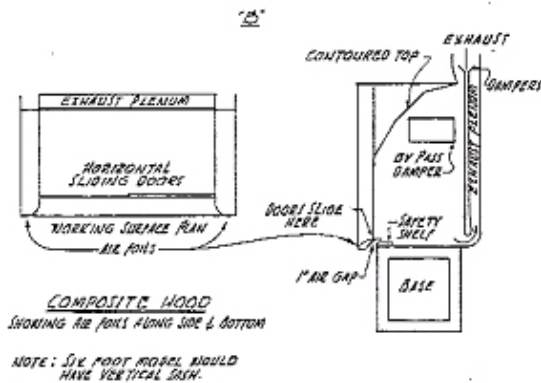


Figure 3 - Cross-section of Fume Hood

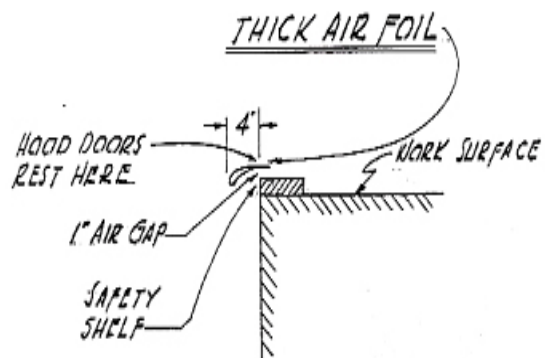


Figure 4 - Enlarged Cross-sectional View of Hood Base

Figure 5 illustrates such a safety shelf arrangement incorporated into an epoxy fume hood base found in a rising sash chemical fume hood. Note that with it, the pan section of the base is displaced approximately 5 inches behind the inside edge of the lower airfoil.



**Figure 5 - Work Surface with 6" Safety Shelf and Lower Airfoil Attached.**

Stockdale then went on stating, **“The safety shelf is one of the most amazing features adopted** [as a result of the extensive hood applications research and development effort then on going at ONRL]. **Without it, heavy fumes lie along the bottom of the hood and creep forward toward the forward edge. Any disturbance there of the inlet-air pattern will draw the fumes into the room** [and user breathing zone]. **With the safety shelf, this troublesome spot is eliminated in the design** [of the fume hood]. “

As Stockdale pointed out **“One additional design feature worthy of mention in a short discussion is the increased depth of the hood. We have increased our hood depth to 30 in. from an average of 24 in. working area, since the safety shelf should not be considered a working surface except as a location to place shielding. The increase depth has an advantage in that it places the work surface farther back in the hood.”**

The sum of the lessons that should be learned from these earlier laboratory engineers and researchers, especially from Stockdale’s presentation are as follows.

Inclusion of a 6 in. wide safety ledge and lower foil of design at least similar to that developed at ONRL should be included in any hood

Owners and users of fume hoods should not, for safety and performance considerations consider or use any part of the 6 in. wide safety ledge as a working surface in a fume hood for two reason: (1) placing items on the safety ledge distorts air flow into and through the hood causing eddies and other disturbances, causes fugitive emission to be drawn to the front of the hood face promoting user inhalation of fumes that escape from the hood; (2) displacing materials back into the cavity of the hood from the hood face allows for greater capture containment within the hood, taking advantage of the same benefit associated with greater hood depth that allows for greater capture containment within the hood with source displacement back away from the user breathing zone in front of the hood.

## **RETURN TO PROVEN CAPTURE CONTAINMENT FUME HOOD VENTILATION CONCEPTS**

More recently, in the past few decades, as properly performing laboratory air flow controls hardware and application technology have evolved, laboratory air flow control systems that include fume hoods have begun to re-embrace and return to the concept of best capture containment ventilation. This resulted from constant fume hood face velocity control at all sash positions. Along with this return, the industry has also begun to re-embrace and return to the use of vertical rising sash hoods, complete with sash caps and hood

inlet sections. These features aid and promote the uniform flow of air into a fume hood, absent of any disturbances created by the hood inlet. This is done to continue to increase the level of capture containment, and this maximum capture containment ventilation is again being achieved in radio isotopic, chemical and biological work places. Indeed some laboratory owners are converting, “in place”, horizontal sliding and combination sash hoods to vertical rising sashes rebuilding the front section of the hoods and providing better sash and face opening sections. While the motivation behind this is of course greatly improved capture containment safety, something that is compounded and improved when the user keeps the sash in its minimum open position while working in front of the hood or closed when not in front of the hood is a significant predictable and guaranteed energy and operational cost savings that result when the laboratory air flow control system produces true constant face velocity at any sash opening position and the hood is equipped with some automatic or other means that ensure that the sash is closed or at minimum opening at all times. Recognition of such features had shown up in consensus standard with

**NFPA 45 – 2003, Laboratories Using Chemicals** stating

*“6.8.3 Laboratory hood sashes shall be kept closed whenever possible. When a fume hood is unattended, its sash shall remain fully closed” and*

**ANSI/AIHA Z9.5-2003 Laboratory Ventilation** states

*3.1.1.4 Automatic Sash Closers: The following conditions shall be met before using automatic sash closing devices:*

*\* Automatic sash positioning systems shall have obstruction sensing capable of stopping travel during sash closing operations without breaking glassware, etc.*

*\* Automatic sash positioning shall allow manual override of positioning with forces of no more than 45 [N] mechanism (10 lbs.) both when powered and during fault modes during power failures.*

While the idea of keeping the sash closed or at its minimum opening is a valid safety goal, the developments of automatic sash closure devices have been proposed for some time. What is new is the installation of an interference sensor mounted on the bottom of the sash for obstruction sensing, purported to have “...obstruction sensing capable of stopping travel during sash closing operations without breaking glassware, etc<sup>4</sup>” with this perhaps meriting some review before blanket endorsement by AHIA, NFPA and open armed acceptance by owners.

## **CURRENT OBSTRUCTION SENSING TECHNOLOGY AND HARDWARE**

Currently one obstruction sensing hardware scheme associated with moving sash interference detection is manufactured and, because of patent protection<sup>5</sup>, available in the market place. The device consists of a photo eye mounted to the bottom of the sash as is illustrated in Figure 6.

---

<sup>4</sup> see <http://www.newtechtm.com/html/asps.htm> and <http://www.newtechtm.com/html/aspsenergy.htm>.

<sup>5</sup> RC Associates Distributing, LLC, Saginaw, MI, Lane A. Bentsen, President, is the exclusive marketing agent for New-Tech™, Inc’s, Midland MI, automatic sash positioning system with reference acronym ASPST™. New-Tech typically includes a statement in its publishing literature to the effect that its advertised products, especially its ASPS is “..covered by one or more of the following New-Tech™ patents: 6,024,638; 5,759,096; 5,303,659; 4,774,878; 4,667,353; 4,594,742; 4,502,375 and other U.S./Foreign Patents Pending.” As New-Tech is not the only manufacturer of an automated fume hood sash position system, this claim as worded might be interpreted as a false and misleading ascertain, done in violation of the Landerman Act. New Tech patent No. 6,024,638 does grant exclusive use of their photo eye moving sash interference detector scheme with their trimodal piston driven sash operator which they claim as an improved “...by the addition of a travel interference system for the moveable sash to prevent accidents and the possible breakage of glassware and the like” with their sash positioning system however, which represent a concept of questionable benefit as discussed herein.

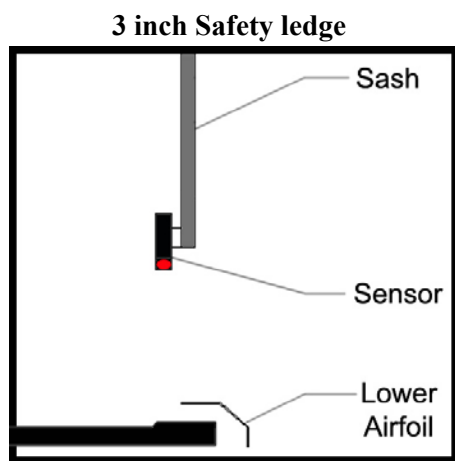
See <http://patft.uspto.gov/netacgi/nphParser?Sect1=PTO1&Sect2=HITOFF&d=PALL&p=1&u=/netahtml/srchnum.htm&r=1&f=G&l=50&s1=6,024,638.WKU.&OS=PN/6,024,638&RS=PN/6,024,638>



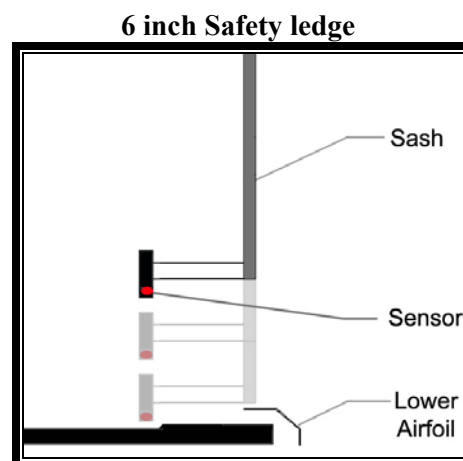
**Figure 6 - Photoelectric Sensor Attached to the Bottom of the Sash**

The photo eye transmits a beam that expand conically away from the transmitter with the beam hitting a reflector on one side of the hood and being reflected back to the transmitter/sensor. If the reflected beam is broken, much like a garage door closer, the transmitter/sensor disengages the power to the motive capability for the moving sash and either stops the sash motion or reverses it. This is done of course to prevent the sash from coming down on top of something that has been left on top of the lower air foil or is resting immediately behind the sash foil on the safety ledge. The unforeseen difficulty that defeats this purported safety improvement feature and turns in into a products liability situation however results when some item like a glass stirring rod or thermometer sticks up from a device and slips can slip between the back of the sash and the reflected light beam emitted from the transmitter/sensor. When this situation occurs, and it has been observed, the sash projected member, acting as a leveraged arms, can cause the glassware where it is residing to flip and spill its contents, typically flipping the beaker or flask forward with contents out of the hood, often on to the user. When the conditions are right for this to occur, i.e., an under eye detector being installed on the cavity side of the hood such as is shown on Figure 6, a negative and defeating hood design and owner use practice has already precipitated it. The owner flaw stems from allowing hood users to place items on the lower foil or on the safety ledge, a forewarned negative situation identified by Stockdale who was properly concerned with safety gained by maximum capture containment in the hood improved by keeping materials off the 6 in wide safety ledge. If safety containment and no user exposure to chemical inhalation resulting from fugitive emission from the hood is an owner goal a zero tolerance proper use safety policy should be established.

To understand the hood design flaw, additional considerations must be given to the types of hood, and more specifically, the bases used with the hoods and how the photo eye is mounted and must interact to arrest sash motion. Figure 7 shows how the transmitter sensor must be mounted if detection is to be achieved. It illustrates that the detection beam must be mounted on the back of the hood sash in such a way that the detection beam “leads” in movement and always proceeds ahead of the lower edge of the sash as the sash closes.



**Figure 7** - Section View of Photo Eye Attached To Bottom of Sash with 3-in Safety Ledge



**Figure 8** - Section View of Sash Closing with 6-in Safety Ledge Allowing Adequate Room for Photo Eye to Rest in Pan

It also requires mounting close behind the back of the hood sash. The transmitter/sensor head must be placed below the bottom of the sash, typically at least one-half inch. The detector must also be mounted inside the hood, behind the sash in such a way that when the sash closes, no interference between the hood base and detector head occurs when the sash comes to rest atop the foil. In some cases this application dictates the width of the safety ledge be reduced typically to about three inches to allow transmitter/sensor mounting without interference with the top of the safety ledge. This is done in such a way that the sensor/detector head can fit down into the pan section of the hood base. Figure 8 illustrates how mounting deeper in the hood cavity must be done when the safety ledge is 6-in instead of 3-in. Herein lies the first problem sometimes associated with this approach, i.e., the device must protrude below the sash and may crash down on the safety ledge if the protrusion is excessive. If the distance between the top of the safety ledge and the bottom of the airfoil is increased, typically from  $\frac{3}{4}$  inch to 2 inches, as has been done in some cases, defeats the original installation purpose of the safety foil and base safety ledge<sup>6</sup>. When applied to a fume hood with a six inch wide safety ledge, the device cannot lead the bottom of the sash by more than a  $\frac{1}{2}$ " inch. This makes the device ineffective with hood bases that have a safety ledge wider than three inches.

The second problem with this device has to do with the under sash reflex photoelectric sensor used and how it works. The device used is a transmitter/sensor<sup>7</sup> that emits a point source of light that spreads conically outward from the sensor. This beam strikes and is reflected by the retro reflector which is mounted at the other end of the sash. This is illustrated in Figure 9 with the beam reflected back and sensed by the transmitter. Because of the circle of influence of the beam spreads along the radial center line axis of the beam, a situation exist where an object sticking out and upward from a container can pass between the back of the hood sash and the edge of the beam undetected.

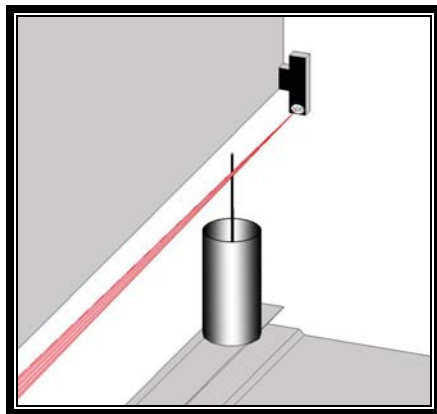
<sup>6</sup> If replication of maximum captures containment ventilation with focus only on the fume hood, CFD modeling studies should be done by fume hood manufacturer for determination of the best hood entrance geometric features to include the contour of the foil, the best shape of the safety ledge entrance and the distance between the bottom of the air foil and the top of the safety ledge. This of course assumes a desire on the part of hood manufacturers to rediscover such parameters as was done via numerous empirical stepwise evaluation experiments done in the 1940s and 1950s atomic energy era.

<sup>7</sup> Electrical Importing Company (E.I.C.) Comet® Series Polarized Reflex with retro reflector is currently used. See [http://www.eicnz.com/old\\_site/eicpg26.htm](http://www.eicnz.com/old_site/eicpg26.htm)

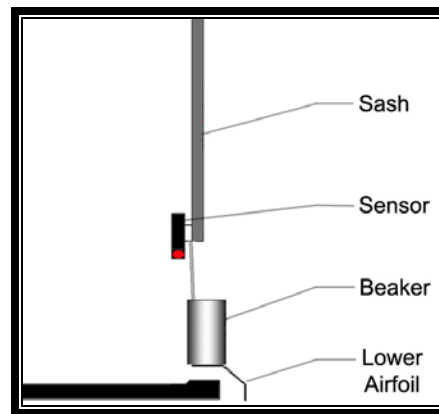


**Figure 9** - *The Photoelectric Sensor Emits a Point Source of Light that is Bounced Back by the Reflector on the Opposite Side of the Sash. The Beam is not Visible and Has Been Added to this Picture.*

The second concern is not properly sensing an element that protrudes around the path of the sensing element. This is illustrated in Figure 10 and Figure 11, which represents a potential spill-causing problem when the photo eye detection scheme fails to sense the stem like protrusion, and the sash closing on the container. The stem like protrusion causes the contents to spill out of or into the hood, depending on stem and container size and placement.

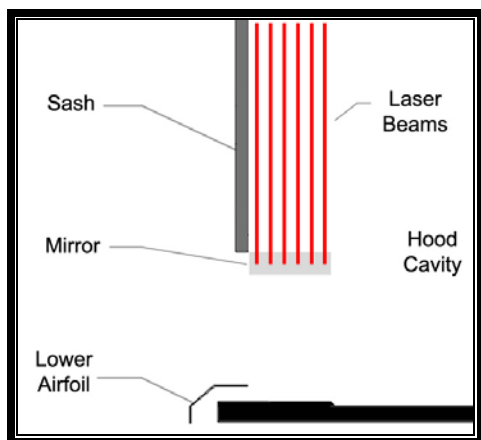


**Figure 10** - *Isometric View of Sensor Not Detecting a Stirring Rod.*

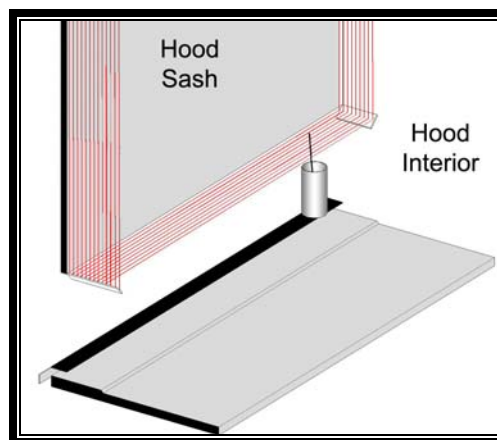


**Figure 11** - *Section View of Sensor Not Detecting a Stirring Rod with 3-in Safety Ledge*

When this occurs the device fails in its intended purpose and, if a personal injury occurs because of container spillage, a personal injury product liability opportunity then exists. A much better scheme for accomplishing this would result if a series of individual but parallel beams, with the individual beams spaced approximately 1/8-inch apart, covering the entire safety shelf were devised and installed to detect an interference problem associated with any element placed on the fume hood safety shelf. This is illustrated in Figure 12 and Figure 13.



**Figure 12 - Full Detection Beam Coverage Across the Safety Shelf.**



**Figure 13 - Laser Beams Reflected off Mirrors Illustrating Protection across 6-in Safety Ledge**

If done this way and with the device applied to a safety shelf of proper 6-inch width as has been suggested earlier, the sash interference detection scheme would then eliminate sash-closing interference with any device atop the safety shelf. This would reinforce the safety goal associated with use of a 6-inch wide safety ledge, which was designed to eliminate placement of any item on the safety ledge by displacing it back into the hood behind the safety ledge on the hood base.

A third concern, also a result from not properly detecting a device, arises when the retro reflector becomes misaligned with the reflected beam not sensed by the transmitter/sensor. Misalignment often happens accidentally, something that renders the detection and interference control goal totally ineffective and useless until corrected. When this occurs the device also fails in its intended purpose and, if a personal injury occurs because of container spillage, a product liability opportunity then exists.

A fourth and more general concern, also resulting from improper detection, stems from the well intended but improper attempt to keep the lenses of the transmitter clean. The lenses of the transmitter/sensor, when wiped with a toluene or acetone moistened chemwipe or cloth, often becomes “cloudy” which obscures the transmitted beam. When this occurs the detection and interference control goal can become ineffective, rendering the device useless.

## RECOMENDATIONS

Since the lower foil, fume hood base, and the safety ledge associated with the base have such a significant impact on capture containment ventilation performance as a means to prevent fugitive emission outflow into the user breathing zone, it is recommended that all fume hoods produced by manufacturers and procured by users include 6-inch safety ledges as a part of the hood base design.

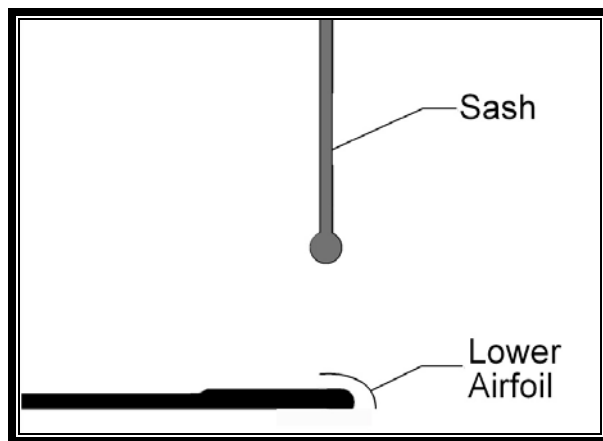
Base design and geometric features should adhere and be consistent with information tested and developed as earlier published in the 1940s and 1950s atomic energy era. If devices such as heaters and ovens need to be installed in a hood, then the depth of the hood should be increased from 24 to 36 inches or more to accommodate such installations, leaving, in all cases, the 6-inch safety ledge clear of any obstructions.

Owners of fume hoods should incorporate zero tolerance proper use policies concerning setting any items on the 6-inch wide safety ledge. Doing so would certainly forgo any added cost associated with use of a device or concept that did not produce promised safety results under all operating conditions.

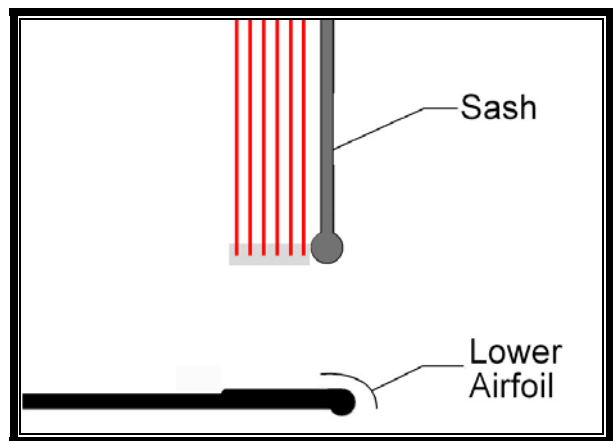
All standards promulgated and issued by consensus industrial or trade groups should be modified to recommend and endorse the use of 6-inch wide safety ledges and the set back feature gained with these type bases, forgoing any endorsements or promotion of obstruction sensing devices associated with any

automated sash positioning systems that improperly claim they are capable of stopping travel during sash closing operations without breaking glassware, etc. With such endorsement, with wording meant to benefit only one manufacturer, should a beaker of hydrofluoric acid, for example, be spilled on a user because of improper or failed obstruction detection, such agency or standard endorsement might be considered as an act of contributor negligence on the part's standard publisher. Should a personal injury suit develop, it could involve the owner, the laboratory design professional, the product representative and manufacturer and any agency issuing standards promoting such an ill-considered concept. With an owner adopting and enforcing installation of fume hoods with 6-inch wide safety ledges and the adoption and use of a zero tolerance policy regarding not setting any items on the safety ledge, this aspect associated with the proper use of a fume hood would, with proper labeling on the hood, revert back to properly place the responsibility of proper hood use on the user.

Finally, three points concerning improvement are suggested. First the fume hood should be considered, purchased, procured, and installed under Division 15 as a capture containment device with aerodynamic foils and features and considered as an element of the laboratory air flow control system with sole system goal of capture containment ventilation; it should not be considered, treated or selected as a piece of furniture with appearance judged on the basis of aesthetics. And, second, if capture containment within the hood is the safety goal, a rounded under sash air foil with rounded safety ledge leading elements as shown in Figure 14 should be included as a part of the fume hood base. This enhancement capitalizes on and makes proper use of the "Coanda Effect"<sup>8</sup> where a stream of air seeks to attach and remain in contact with solid boundary. Figure 15 illustrates a further improvement with this same aerodynamic enhancement that is preferred and should be incorporated in to a fume hood base if one seeks to maximize only the foiled section and the hood base capture containment related aspect of the fume hood.



**Figure 14 - Foiled Section and Base with Rounded Section on Bottom of Sash.**



**Figure 15 - Fully Round Base Air Entrance with Laser Array Sensing Capabilities 6-in Safety Ledge**

Other aspects and features of fume hoods that can be improved to enhance global fume hood performance capture containment exist.

<sup>8</sup> "Coanda Effect" was discovered in 1930 by the Romanian aerodynamicist Henri-Marie Coanda (1885-1972). It explains that if a jet of air is projected parallel to and within a few inches of a solid surface how that surface will affect the jet. The surface creates a low-pressure region along the solid surface and tends to attach the jet flow to the surface. The slightly higher pressure atop the jet within the hood cavity tends to hold the jet against its adjacent surface. This phenomena explains why the hood base and lower hood with even a slight flow between them is so successful in "sweeping" the base of the hood in a way that promotes and enhances capture containment in the hood. The Coanda effect also explains why round fume hood sidewall section and the lower edge of the sash should be rounded. See <http://jnaudin.free.fr/html/coanda.htm>

## ABOUT THE AUTHORS

Swiki A. Anderson is President of Swiki Anderson and Associates, Inc. (SAAI) Bryan, Texas and president of Accu\*Aire Controls, Inc., a laboratory air flow control system that grew out of mockup testing and other laboratory air flow research work done by Swiki Anderson and Associates, Inc. Before formation of SAAI, he was an associate professor of Mechanical Engineering at Texas A&M University. In 1980, he left the University to perform mock-up testing and controls consulting to Exxon Research and Engineering Company. He has continued doing applied research and has been principal in charge of several of Swiki Anderson and Associates' design activities with various large laboratory airflow control systems. He has served on ASHRAE TC4.1, Load Calculations; served as a chairman for "Task Group on Airflow Round Buildings"; and was a member of ASHRAE SPC 110, "Methods of Testing Performance on Laboratory Fumehoods."

Barrett Schulz is employed at Swiki Anderson and Associates working with graphics. He is working towards his bachelor's degree in Environmental Design from Texas A&M University.